

HOUDINI

Marine Windows, Hatches and Doors

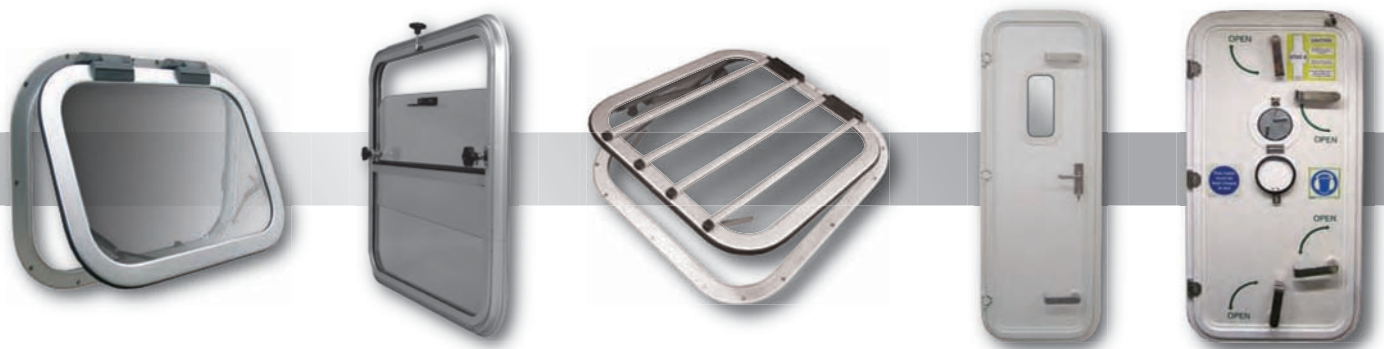

HOUDINI MARINE WINDOWS LTD.

Houdini Marine Windows Ltd. have over 40 years experience of designing and developing bespoke windows, doors and hatches for marine applications.

Investment in new technologies, combined with extensive knowledge of the marine environment gives you the confidence that your Houdini products will be of the highest quality.

At Houdini we understand that the shape and styling of windows, doors and hatches are vitally important. Our skilled work force take pride in designing and manufacturing products that compliment and enhance the vessel's overall appearance.

We provide windows for a wide variety of vessels ranging from passenger ferries and all types of commercial craft to sailing yachts, motor yachts and leisure cruisers – in fact any kind of boat. Also available are our sturdy doors, deck hatches and windscreens. In addition, we can offer windows suitable for non-marine use, such as vehicles, laboratories and oil rig drilling cabins.

We export to markets in Europe, Scandinavia, Africa, the Middle East, Russia, the Far East and Australia.

Our products are designed to comply with international safety and performance standards, and our service is designed to ensure your requirements for vision, ventilation and light are met.



INVESTMENT IN TECHNOLOGY



Houdini continue to make significant investments in equipment and new technology as we strive to improve our designs and product quality. The recent addition of a CNC bending machine has allowed us to form windows to a much higher accuracy than previously possible. This gives us the ability to consistently produce high quality and identical products and we are now manufacturing windows for one customer to a tolerance of 0.5mm. This machine also allows us to achieve significant savings which can be passed onto the customer when there is a sizeable quantity of windows required.

All images were correct at time of printing. We reserve the right to change details as our products evolve.

CONTENTS



How To Buy Houdini Products	4-5
Fixed Windows	6
Sliding Windows	6
Direct Bonded Windows	7
Frameless Hinge Out Windows	7
Hinged Windows	8
Half-Drop Windows	9
Full-Drop Windows	9
Combination Windows	10
Windscreens	11
Companionway Hatches	11
Houdini Deck Hatches	12
Light Duty Doors	13
Heavy Duty Doors	14-15
Bulkhead Sliding Doors	16
Interior Doors	17
Patio Doors	17
Non-Marine Applications	18-19
Data Sheets	20-25
Moonlight Hatches	26-27

HOW TO BUY HOUDINI PRODUCTS

How much will they cost?

All of our products are built to your individual specifications and comply with the ISO12216 standard for marine glazing requirements. To obtain a quotation, please provide us with the following:

1 Your Contact Details

Your name, company, address, phone/fax numbers and email address.

2 Product Type & Quantity

The quantity and type of each item required. For clarity please use the product type descriptions illustrated on this page. Details of each product type are given on pages 6-17.

3 Vessel Details

- Size and type of vessel
- Intended area of use (offshore, coastal or inland waters)
- Structure of the vessel (steel, aluminium, wood or GRP)
- Structure thickness

4 Size, Shape & Corner Type

Approximate dimensions of each *aperture*. Please provide a dimensioned sketch for each item to clearly illustrate the shapes and sizes of the required apertures. Remember that sliding windows must have parallel edges or have a bar fitted to ensure a parallel slide. The sketches should show the type of each corner required (mitre or radius).

5 Frame Finish

Our high quality aluminium frames can be supplied in a wide variety of finishes to blend with the overall design or to match existing window finishes. As standard, frames are supplied as silver satin anodised, as this is the most hard wearing finish available for marine applications. Alternatively a wide range of very durable coloured powder coat finishes can be applied. Please specify silver satin anodised or powder coated.

6 Glazing

As standard we fit glass toughened in accordance with EN12150. Other toughened glasses, for example ISO614 (specification for ships' windows), can also be supplied.

Please specify:

- Glazing thickness
- Glazing finish - clear or tinted (blue, bronze, green or grey)
- Single or double glazing
- Specialist glazing - electrically heated glass, bullet proof glass, reflective glass, Makrolon®, acrylic, or screen-printed for direct bonding into the vessel structure

7 Frame Section

Houdini has a wide range of framing systems available, including modern clamping styles that do not need any drilling of the vessel structure. Clamping windows have the benefit of being easier to fit than the traditional through-fix (bolt on) frames, but they are not suitable for all types of installation. For details of these frame systems see the data sheets on pages 20-25 of this brochure.

Please specify the frame section and backing trim required.

We are happy to discuss your requirements to help you find the right solution.

These details can be provided by telephone, or preferably by fax or email. Our standard quotation form can be downloaded from our website www.houdini-marine.co.uk.

Fixed Window



Sliding Window

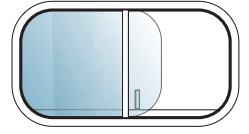

Hinge Out Window



Hinge In Window



Part Hinge Out Window

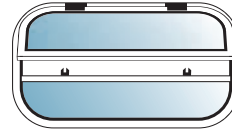

Full Drop Window

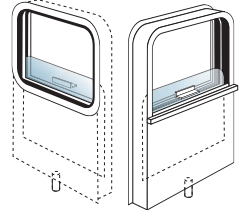

Half Drop Window

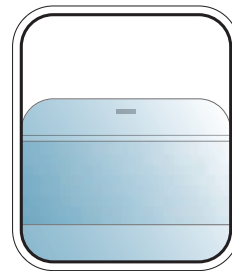

Hopper Window

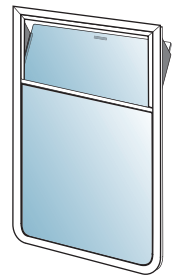

Combination Window



Windscreen

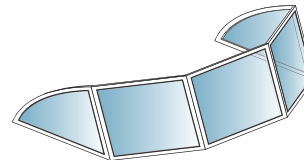

Bespoke Hatch



Sliding Bulkhead Doors

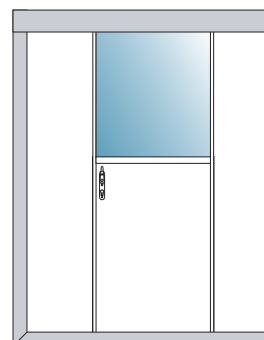

Hinged Doors



How to order

For windows, bespoke hatches or doors either send us a drawing (CAD or hand drawn) or a template of the aperture in the vessel structure.

For windscreens, we require a plywood template that has been made and fitted on the boat.

If emailing us a CAD drawing, please send it in DXF format.

If making a template of the aperture into which the window will be fitted, please use plywood, hardboard or good quality paper. Do not cut out the template, as it is easier for us to measure a drawn line.

Mark on the drawing or template:

- Aperture dimensions in millimetres. This is to check that there is no shrinkage in the template material
- Whether aperture is marked from inside or outside the vessel
- On drawings please specify the aperture radii required
- The location on the boat (for a window mark it forward or aft, the top, and port or starboard)
- Windows only - position of any openings or mullions required
- Doors only - position of hinges and, if required, the position of fixed or opening windows

With your order state:

- Your contact details
- Type of window or door
- Quantity
- Vessel details – size and type of vessel, intended area of use (offshore, coastal or inland waters), structure of the vessel (steel, aluminium, wood, GRP) and structure thickness
- Frame finish
- Glazing thickness, finish and whether single or double glazed units are required
- Specialist glazing requirements – electrically heated glass, bullet proof glass, reflective glass, Makrolon®, acrylic, screen printing
- Frame section and optional backing trim



Once we receive this information, we use our CAD digitiser to convert the information onto our CAD system. A manufacturing template is produced that is a full sized pattern of the specified window. This pattern is sent to you for checking, allowing visual confirmation of the size and appearance before manufacture commences. This provides you with the opportunity to check that instructions have been correctly interpreted and give final approval for the order to be manufactured.

Additional information such as closures, hinge placing and opening sections of the window will also be shown on the pattern. Any corrections or amendments can be carried out quickly and easily on the CAD system at this stage.

Once final approval of the drawing has been received we can also provide you with a paper cutting template for the required aperture.



Window silencer



Heavy duty cast stainless steel hinge



Moulded nylon hinge



Deck hatch casement handle



Bridge handle



Hopper catch



Screw down (6mm)



Screw down and finger pull



Slam lock

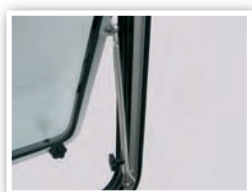

Stainless steel sliding stay



Gas strut



Adjustable stay arms



Deck hatch ventilation stay

FIXED WINDOWS

Fixed windows are our most popular product, available in many shapes and sizes to suit any application.

We can supply these windows using either our through-fix or clamp section frames (see data sheets on pages 20-23).

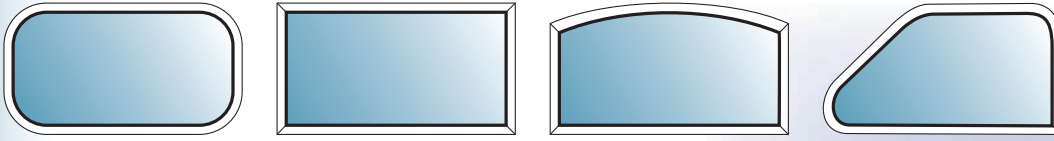

Features

- Glazing is wet sealed into the frames to ensure a joint-free long lasting weatherproof seal
- Where mitred corners are required along the lower edges of a window, we normally weld the mitre joint to ensure maximum strength, rigidity and watertightness

Options

- Both single and double glazed fixed windows are available
- Fixed windows can be supplied pre-cut for a clear view screen to provide maximum visibility in inclement weather. Please advise us of the make and model of your clear view screen and we will ensure the cut-out is a perfect fit
- We can supply electrically heated glazing to minimise misting and provide defrosting

Glazing Curved Surfaces

Fixed and direct bonded windows can be fitted to slightly curved structures, depending on the thickness of glass. For example, with 6mm glazing the curvature can be up to 3% (10mm out-of-plane for every 300mm length) which is adequate for most vessels.

SLIDING WINDOWS

Sliding windows are ideal for maximising ventilation and are usually fitted to the side of a vessel, facilitating communication between a wheelhouse and crew working on deck. They are available in many shapes and sizes to suit any application. We can supply framed sliding windows using either our through-fix or clamp section frames (see data sheets on pages 20-23).



Features

- Fixed glazing is wet sealed into the frames to ensure a joint-free long lasting weatherproof seal
- Sliding panes in frame sections D, HD, W and Lite Clamp run on flock channel, a velvet lined rubber extrusion
- Sliding panes in frame sections Clamp 6-8 and Clamp 10-12 run on a convex hard plastic extrusion with brush seals around the glass to reduce friction, enabling free and easy sliding movement even with the largest and heaviest windows
- Where mitred corners are required we always weld the bottom mitre joint to ensure that any water collecting in the lower channels cannot leak through the joint
- All sliding window frames are drained through slotted scuppers in the lower frame section, with scupper covers fitted to prevent wind pressure forcing water back inside the frame
- All sliding window handles are bolted through the glass to ensure a sturdy fixing
- As standard, the aft pane of glass slides forward in the inner channel to maximise the weather tight performance of the window

Options

- We can design the window so that the forward pane slides aft in the outer channel of the frame
- Sliding/closing handle options are slam lock, bridge handle, or screw down and finger pull in small (6mm) or large (8mm) sizes



DIRECT BONDED WINDOWS

Direct bonded fixed windows do not have frames and are bonded directly to the vessel structure. This glazing technique is becoming more popular with production boat builders and with designers as it allows striking shapes to easily be created with clean attractive lines.

When direct bonding glass into a boat the edge of the glass should be screen-printed with a ceramic frit, similar to those found on car windscreens, to prevent ultra violet degradation of the adhesive. The initial set up costs of the screen-printing mean that this technique is normally only cost effective for volume production runs.



Features

- Frameless glazing is bonded directly onto the outside of the vessel
- Glazing can be cut to complex shapes allowing for more radical styling than can be achieved with a framed window

Options

- Width of the solid black ceramic band around the edge of the glass can be varied to suit the styling requirements of the boat

Glazing Curved Surfaces

Fixed and direct bonded windows can be fitted to slightly curved structures, depending on the thickness of glass. For example, with 6mm glazing the curvature can be up to 3% (10mm out-of-plane for every 300mm length) which is adequate for most vessels.

FRAMELESS HINGE OUT WINDOWS

These windows have been designed specifically for use alongside direct bonded windows. The frame is concealed by the glazing to give a frameless appearance, allowing the visual lines of the glazing to remain unaffected. The current system has been developed for double-glazed units, providing greater sound and thermal insulation than single-glazed windows.



Features

- Frame screwed or bolted on from the exterior for ease of fitting and to match the interior appearance of direct bonded windows
- Black anodized concealed frame
- All corners mitred and welded
- Double synthetic rubber seal for outstanding watertightness
- Stainless steel hinges
- Stainless steel gas struts to support the open window
- Casement handles for ease of closure
- Double glazed screen printed unit fitted in window



HINGED WINDOWS

Hinged windows can be used for many applications on most types of vessel. They are generally fitted to the forward facing superstructure and allow the benefits of maximum ventilation and visibility with total watertightness. We have an extensive range of adjustable friction stays that we use to hold the windows in an open position and we can also fit gas struts to help with the opening of larger and heavier windows.



Hinge out windows are also commonly supplied as secondary emergency exits with handles that allow opening from both inside and outside the vessel.

Windows can be fully or partially hinged (with the remainder of the window fixed) and are available in most shapes and sizes.

We can supply hinge out windows using either our through-fix or clamp section frames (see data sheets on pages 20-23) and all of the hinged windows feature the use of synthetic rubber seals for maximum sealing properties.



Features

- Glazing is wet sealed into the frames to ensure a joint-free long lasting weatherproof seal
- The joints in the base frame are welded to ensure water tightness and rigidity
- The hinged window closes against a top quality synthetic rubber section to ensure an excellent seal

Options

- Windows are securely closed using heavy duty thumb screws or casement handles
- Both single and double glazed hinged windows are available
- Hinges can be in reinforced moulded nylon or stainless steel
- Larger hinged windows can be supported in their open position by either gas struts, stainless steel adjustable stays, or aluminium adjustable stays
- For irregular shaped windows the stays are ball-jointed to ensure smooth operation
- Hinge in windows are also available



Side hung emergency exit

HALF-DROP WINDOWS

Half-drop windows provide ventilation without intruding on interior space or extending into external deck areas. Like sliding windows they are unlikely to foul lines and do not impede the movement of passengers or crew members along the side decks. We recommend half-drop windows only when the height of the required window is greater than the width. We can supply half-drop windows using either our through-fix or clamp section frames (see data sheets on pages 20-23).

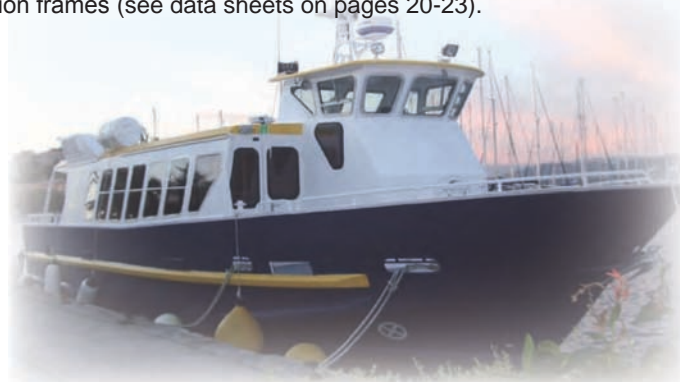
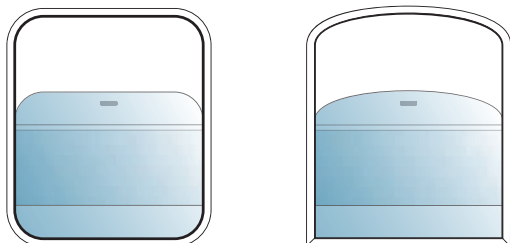

Features

- Fixed glazing is wet sealed into the frames to ensure a joint-free long lasting weatherproof seal
- Where mitred corners are required we always weld the bottom mitre joint to ensure that any water collecting in the lower channels cannot leak through the joint
- For smaller windows the friction of the seals is sufficient to hold the opening section in any position. For larger windows the opening section can be secured in any position by window silencer locks which also minimise rattling
- All handles are bolted through the glass for strength and durability

Options

- A half-lift option is available, with a rack and spring-loaded catches to provide a number of fixed opening positions that do not rely on friction or silencer locks
- Sliding/closing handle options are slam lock, or screw down and finger pull in small (6mm) or large (8mm) sizes

FULL-DROP WINDOWS

Full-drop windows are popular in many commercial vessels where large opening windows are advantageous for ventilation and communication with the crew working on the deck. The windows are particularly suited to fitting to the side of wheelhouses so there is no obstruction of the side decks when the window is open.

The window fits internally in the boat and the glass drops down into its own self contained watertight box below the aperture in the structure. The watertight box is drained by a hose back outside or into the bilges. Please note that you have to make provision for routing of the drain hose. We offer two types of full-drop window:

Weather Tight Full-Drop Window - available in through-fix frame sections (see data sheets on pages 20-21) with standard seals and optional silencer locks.

Watertight Full-Drop Window - allows the operator to make the closed window watertight by clamping the glass against a synthetic rubber seal. The watertight full-drop window is only available in clamp frame sections (see data sheets on pages 22-23) for ease of installation.

Features

- A wiper blade type seal is fitted to the outside face of the sliding glass to provide a high degree of weather tightness. Any water that does get around this seal automatically drains into the watertight box below the window where it can be drained back outside
- All handles are bolted through the glass for strength and durability

Options

- A counterbalance system can be fitted into the watertight box to allow easy opening of large heavy windows
- For smaller windows the friction of the seals is sufficient to hold the opening section in any position. For larger windows the opening section can be secured in any position by window silencer locks which also can be used to tighten the glass against the seals for increased weather tightness
- Sliding/closing handle options are screw down and finger pull in small (6mm) or large (8mm) sizes

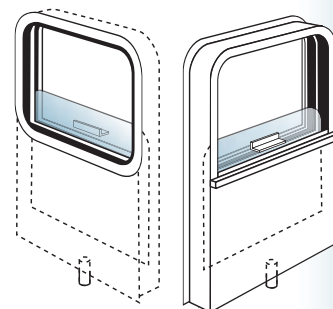

COMBINATION WINDOWS

Combination windows allow for a mixture of fixed and opening sections, all within the same outline frame.

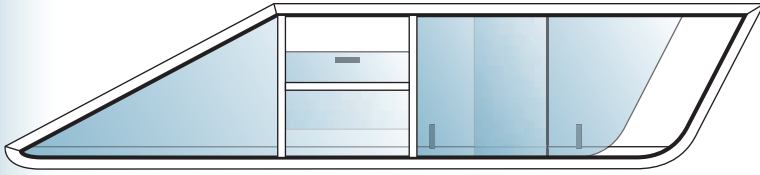

These are particularly suited to irregularly shaped installations designed to complement the lines of the vessel. There are a few guidelines which must be followed, but generally an attractive solution can be designed that meets the aesthetic requirement whilst providing the functional benefits of sliding, half-drop or hinged opening windows.

Please contact us and we will be happy to discuss your combination window requirements and suggest designs that are both elegant and practical.

Features

- Fixed glazing is wet sealed into the frames to ensure a joint-free long lasting weatherproof seal
- Where mitred corners are required along the lower edges of a window, we normally weld the mitre joint to ensure maximum strength, rigidity and watertightness

Options

- Both single and double glazed combination windows are available depending on the configuration of the required window



HOPPER WINDOWS

Hopper windows are suitable for both inland and coastal waters vessels. They are particularly popular on inland waterways vessels as, when open, they provide ventilation without water ingress during inclement weather. We can supply hopper windows using either our through-fix or clamp section frames (see data sheets on pages 20-23).

The top corners of the opening section must have mitred joints.

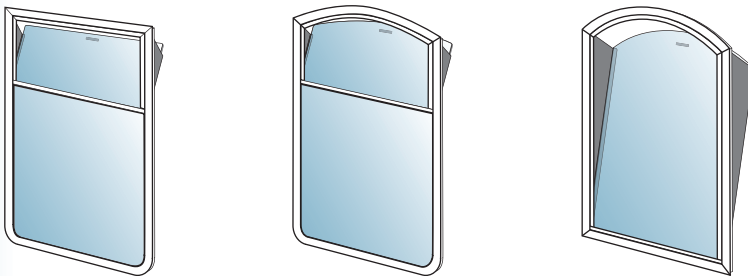

Features

- Fixed glazing is wet sealed into the frames to ensure a joint-free long lasting weatherproof seal
- Windows are securely closed using a spring-loaded camlock
- Where mitred corners are required at the bottom of the window, we always weld the joint to ensure that any water collecting in the lower channels cannot leak through the joint

Options

- Both single and double glazed hopper windows are available



WINDSCREENS

Houdini manufacture stylish and practical windscreens for all vessels where the windscreen is constructed from multiple flat panels. The complex three dimensional shapes that are produced necessitate the use of plywood templates that have been fitted to the boat. This not only allows you to see the overall lines of the vessel with the windscreen template in place, but also ensures that the finished product will fit the vessel and meet your requirements.

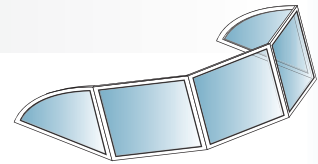

Features

- All screens fitted with 6mm toughened glass
- Easy installation - all panels slot together with removable stainless steel pins
- Top rails feature an aluminium bar for permanent fixing of canopy fastenings
- We only manufacture flat panel screens

Options

- Windscreen wipers
- Handrails can be fitted to the top of the screen (subject to panel size)
- Cables for lighting or wipers can be run inside the frame or routed through a conduit
- Screens can be made to fold down flat for bridge clearance
- Screens can be made removable
- Door panels can be provided in the screen (bow rider boats)
- Centre panels can be hinged for ventilation

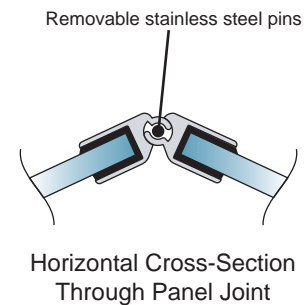
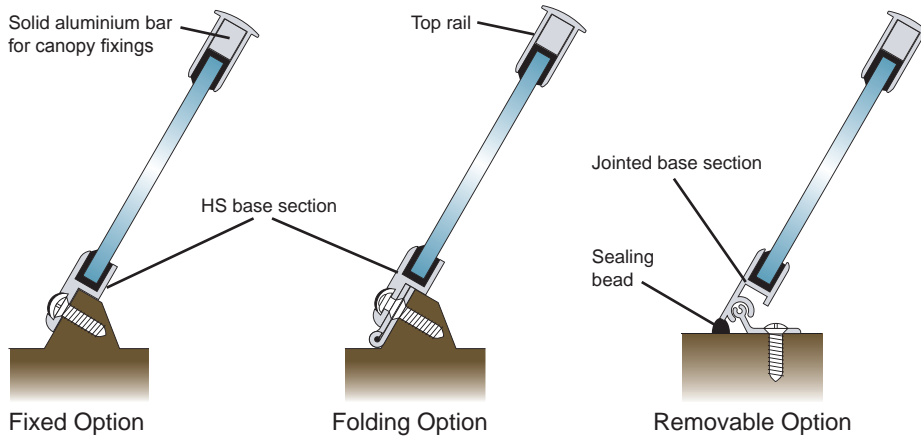

COMPANIONWAY HATCHES

We have developed a self contained sliding companionway hatch that is fitted with toughened glass and acrylic. This allows huge amounts of light into the cabin in comparison to the traditional sliding GRP hatches, as well as providing a much more weather tight sealing arrangement. Ideally this hatch is fitted to a GRP moulding that has been designed for it, which allows it to fit flush to the deck. The hatch can be supplied as a retrofit, but it must then mount on top of the deck.

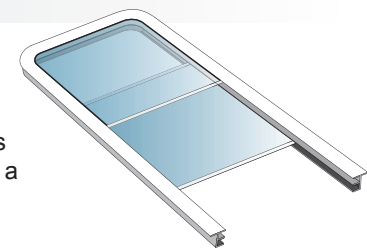

Features

- Fully glazed sliding companionway hatch for maximum light
- Fitted with 10mm grey toughened glass fixed section and 10mm grey acrylic sliding section
- Aluminium interior and exterior handles

Options

- A self contained drained hatch
- Acrylic washboards with aluminium frames
- High quality stainless steel and moulded nylon lock

We also combine hinged doors and hinged or sliding hatches to provide access from a flying bridge to the cabin below.



HOUDINI DECK HATCHES

The world renowned and instantly recognisable Houdini deck hatch has been in production for over forty years. There are few marinas in the world where you cannot find boats fitted with Houdini hatches.

Our hatches are robustly constructed using quality materials and are fitted with toughened glass. When compared to acrylic glazing, used in most deck hatches, toughened glass will not scratch as easily or suffer UV degradation. This means that the hatch will maintain its appearance and give many years of trouble free service.

Houdini hatches enjoy a reputation for being functional, watertight and economically priced.

The most popular sizes are Model 3, often referred to as the 'Mini Hatch' and Model 5, the 'Super 50 Hatch'. With an above deck height of a mere 25mm these hatches are extremely streamlined and cause minimum obstruction on the deck.



Model 5 (500mm x 500mm)
Super 50 Hatch in silver satin finish

MODEL	NAME	APERTURE SIZE (mm)	APERTURE RADIUS (mm)	OVERALL SIZE (mm)	CLEAR OPENING SIZE (mm)	GLASS THICKNESS (mm)	VENTILATION STAY	OPTIONAL ADJUSTABLE STAYS
1		250 x 250	75	284 x 284	220 x 220	6	•	
2		350 x 200	75	384 x 234	320 x 170	6	•	
3	Mini Hatch	450 x 320	100	484 x 354	420 x 290	6	•	
4		500 x 370	100	534 x 404	470 x 340	6	•	
5	Super 50 Hatch	500 x 500	100	534 x 534	470 x 470	6	•	•
6		620 x 620	100	654 x 654	590 x 590	8		standard

Features

- Hatches are CE marked for compliance with ISO12216 standard
- Marine grade aluminium (HE9), silver satin anodised as standard
- Aluminium alloy safety bars
- All joints sealed against ingress of water, fish-plated and screwed
- Seal is extruded synthetic rubber
- Grey tinted toughened glass fitted as standard
- Two casement handles



Model 4 (500mm x 370mm)
Hatch in silver satin finish

Options

- Clear, obscured glass or bronze, green, and blue tints available
- Multi-position adjustable ventilation stays for hatch model 5
- Can be supplied without safety bars
- Frame - coloured powder coat or matt gold anodised
- Backing trims - Type 1, 2 or 3



Model 3 (450mm x 320mm)
Mini Hatch in black powder coat finish

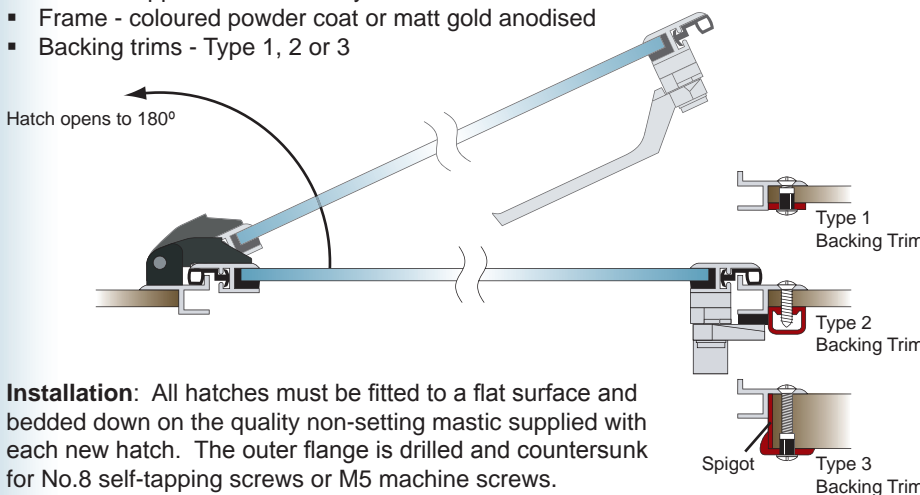

Installation: All hatches must be fitted to a flat surface and bedded down on the quality non-setting mastic supplied with each new hatch. The outer flange is drilled and countersunk for No.8 self-tapping screws or M5 machine screws.



Bespoke tapered deck hatch in silver satin finish with ball-jointed adjustable stays and 3 screw-down locks

Type 3 Backing Trim Aperture Size: For Type 3 backing trim and spigot all aperture sizes and aperture corner radii must be 3mm larger. For example, for a Model 5 hatch with a nominal aperture of 500mm x 500mm and an aperture corner radius of 100mm, the aperture must be cut to 503mm x 503mm and the corner radii must be cut to 103mm.

Replacement Seals: As boats age, window seals deteriorate. Should you require a replacement seal, please contact us.

Bespoke Hatches: In addition to the standard range we are able to build the Houdini Hatch to match existing apertures. Bespoke hatches can be manufactured with radiused or mitred corners, and can be trapezoidal, rectangular or square in shape.

LIGHT DUTY DOORS

The light duty door provides an economical option for a lightweight internal door or a sheltered external door.

Features

- Doors come complete with hinges and locks fitted and employ clamp frame technology which requires no drilling of the vessel's structure, ensuring quick and easy installation (see data sheet on page 24)
- Frames are marine grade aluminium alloy and all joints are fishplated and screwed together
- Hinges are moulded nylon with a stainless steel pin
- Handles without locks are fitted as standard
- Door panels are made from a GRP/foam composite panel with aluminium frame for stiffness, durability and excellent strength to weight ratio
- Synthetic rubber seal fitted to door to provide a good degree of watertightness
- Standard fixing frame will fit structures from 3 to 25mm thick
- Outward opening only

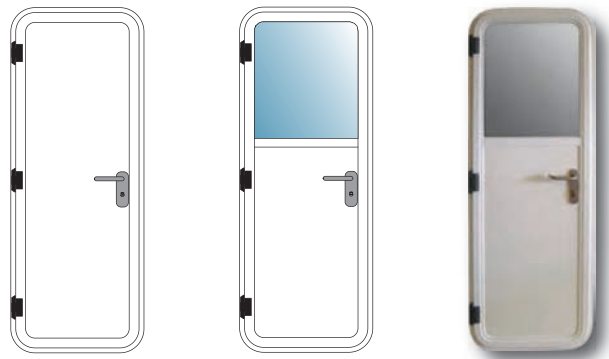

Standard handle



Standard handle with key lock

Options

- Doors can be provided with a glazed top panel in the door
- Corners can either be mitred or radiused (aperture corner radius 100mm)
- High quality all stainless steel mortice locks can be supplied with key locks or toilet privacy locks
- These doors cannot be provided with dogs

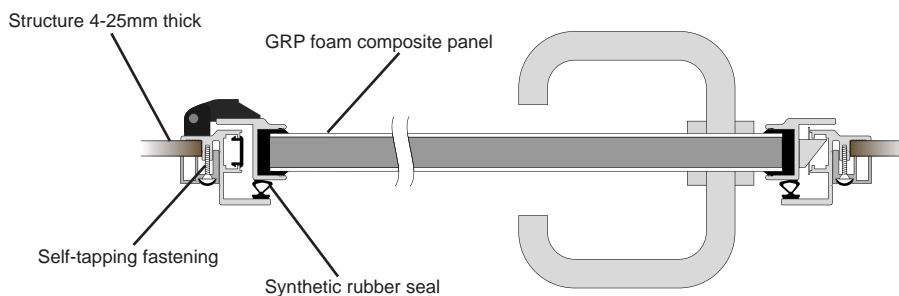

HEAVY DUTY DOORS

The Houdini heavy duty door is perfect for use on offshore vessels operating in harsh environments and where a high degree of weather tightness is required. The door is robust yet lightweight and practical; all fittings and fixtures have been carefully selected and specified to ensure long-term trouble free operation.

Each door is designed and manufactured specifically to meet your operational requirements.



Features

- Doors come complete with hinges and locks fitted and employ clamp frame technology which requires no drilling of the vessel's structure, ensuring very quick and easy installation (see data sheet on page 24)
- Frames are marine grade aluminium alloy with the joints in the bulkhead frame welded for extra strength
- Door panels are made from a GRP/foam composite with aluminium frame for stiffness, durability and excellent strength to weight ratio
- Top quality stainless steel mortice locks and handles
- Cast stainless steel hinge bodies with phosphor bronze hinge pins
- Double synthetic rubber seals to ensure security and weather tightness
- The standard fixing frame will fit structures up to 25mm thick - thicker structures on request
- Outward opening only

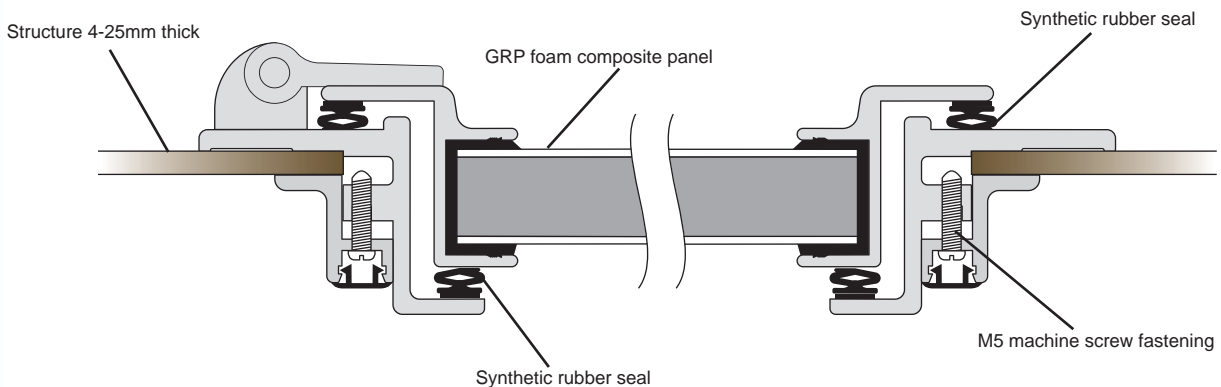



Pilot boat with Houdini heavy duty, watertight, engine room door (vessel above and detail right)



Standard handle with key lock



Heavy duty dog



Heavy duty door hold-back

Options

- Fixed or opening windows
- Half-glazed door incorporating a fixed glass panel in the top of the door (it is not possible to fit dogs into a half-glazed door, a separate window must be specified if dogs are required)
- Corners either mitred or radiused (with an aperture corner radius of 100mm)
- Independently operated dogs
- The number and positions of hinges, dogs and locks can be specified according to size and location of the door and degree of weather tightness required
- Heavy duty hold-backs to secure the door in the open position
- Locks can be keyed alike



BULKHEAD SLIDING DOORS

A new design of weathertight bulkhead sliding doors has been introduced to the Houdini range of door products. These are for fitting to the side or aft end of a vessel's structure and are mounted on the external surfaces (see data sheet on page 25).

Features

- 4 wheel roller hangers made from high performance moulded nylon and stainless steel
- Stainless steel hanger track and bottom guide rail
- Moulded nylon torpedo bottom guides
- High quality stainless steel marine sliding door lock with key operation and thumbturn internal operation
- Stylish aluminium garage with face fixing flange
- Brush seals fitted to garage and back of door to provide weathertightness to door
- Door panels are made from a GRP/foam composite panel with aluminium frame for stiffness, durability and excellent strength to weight ratio
- Only available with mitred corners

Options

- Fixed window or glass panel (single or double-glazed) in top of door
- Locks can be keyed alike

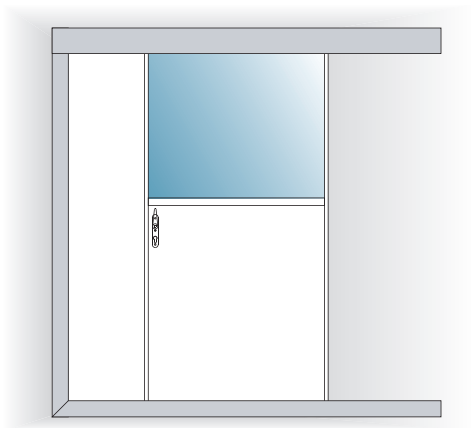

Long and short sliding door stops

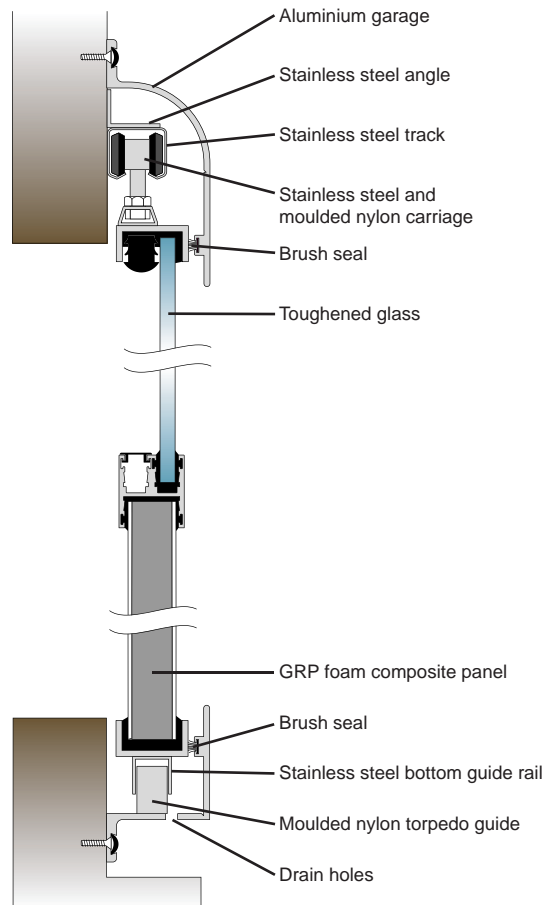

INTERIOR DOORS

In conjunction with some of our non-marine customers, we have designed and produced internal doors for their specific requirements. Recent examples include bi-fold and hinged doors.

Bi-fold Interior Door

Features

- Ideal as interior space saving door
- Large aperture for minimum intrusion into interior space
- Lightweight construction
- Top guide is a roller bearing carriage and track to ensure a free and easy movement
- Quality hook lock fitted as standard

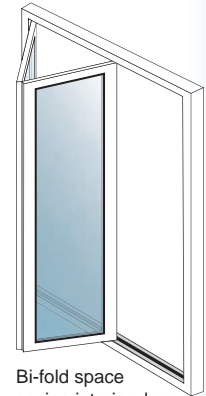

Bi-fold space saving interior door

Hinged Interior Door

Features

- Lightweight construction
- Corners can only be mitred
- Top quality lock fitted as standard

Options

- Fully or part glazed with aluminium panel fitted to bottom of door



PATIO DOORS

Patio doors are popular as a stylish wheelhouse entry on motor yachts, catamarans and inland waterways vessels. They should only be used in applications where there is a high degree of protection from the weather, i.e. facing aft onto the stern deck. They provide excellent access, ventilation and visibility and are both robustly constructed and attractively finished.

Features

- Patio doors can have 2,3 or 4 panels
- Corrosion resistant stainless steel runners and rollers
- Stylish moulded nylon and stainless steel locks

Options

- Face-fastening flange to allow easy installation
- Stop lock to hold the door in the open position
- Anodised or powder coated finish
- Can be supplied as a cranked door to fit the bulkhead
- Single or double glazed, full or half glazed



Cranked patio door

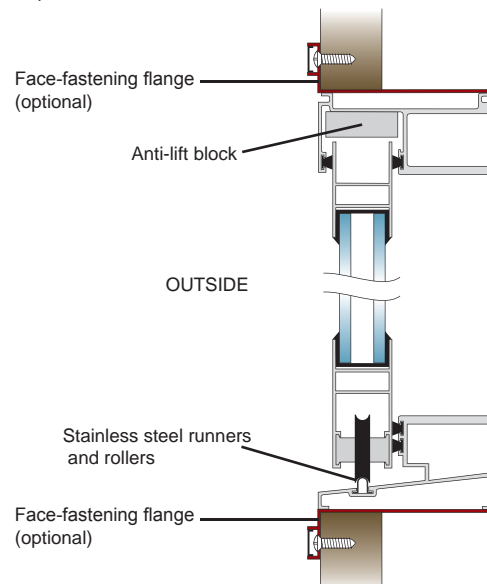
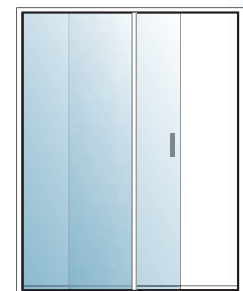

NON-MARINE APPLICATIONS

Houdini also manufactures products for non-marine use. We work with many companies that require specialist glazing for their products.

Examples include:

- Police mobile headquarters
- Mobile library
- Fire truck
- Oil rig drilling cabin windows
- Clean room windows
- Outside broadcast units

Windows may incorporate specialist glazing, for example:

- Reflective glass
- Double-glazed units with integral blinds
- Bullet-resistant glass

Please contact us to discuss the suitability of our products to meet your requirements.



Oil rig drilling cabin



BP Bruce oil rig



Mobile job centre



Outside broadcast unit



Clean room



Window fitted with integral blind

RSPB Project

Houdini have recently completed the design and manufacture of innovative large opening windows for installation in bird-watching hides for the Royal Society for the Protection of Birds (RSPB).

This project involved close co-operation with the RSPB and their architects to develop a window that offered both total and partial opening, and could easily be operated from a seated position to allow full functionality for disabled users. The brief also required that the outside of the glass could be cleaned from inside the hide.

Several prototypes were commissioned and tested in our factory and on site by the RSPB until the design was optimised.

This project demonstrates the ability of our design department to work closely with our customers to match our capabilities to the customer's requirements.

These hides have been installed at RSPB Rainham Marsh and RSPB Titchwell Marsh.



Interior view of the hide, showing the window winders which control the sliding lower panes

The hide windows comprise a lower sliding pane and an overlapping upper hinged pane.

The lower pane slides vertically, dropping into the wall beneath the frame to allow low level photography from a seated position.

The upper pane hinges out to increase the aperture whilst continuing to provide weather protection.



"Houdini Marine had the expertise, commitment and flair to make a success of the new window for RSPB through the prototyping phase and into production."

Patrick Ward
HaysomWardMiller Architects



THROUGH-FIX FRAME SECTION DATA

These require fixing holes to be drilled in the vessel around the edge of the aperture. The frames are usually drilled at between 100mm and 150mm intervals. There are three different interior trim options:

Type 1: A flat interior trim ring which is fixed using machine screws (external) and interscrews (internal).

Type 2: A channel section interior trim which is fixed using self-tapping screws from the outside. There are no visible fixings on the interior frame for the Type 2 trim.

Type 3: Predominantly for thicker wall/hull sections, the Type 3 trim incorporates a spigot (maximum depth 75mm) to cover the inner edge of the aperture and a profiled interior trim ring which is fixed using either machine screws (external) and interscrews (internal) or self-tapping screws inside and outside.

Through-Fix Frame Interior Trim Types

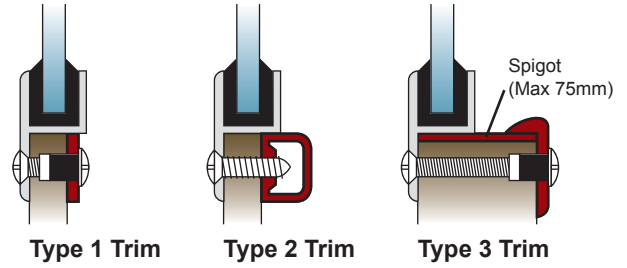

Section S

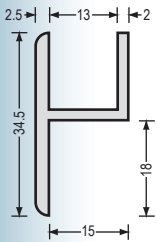

- Bend radii (mm): 47.5/50/57/63.5/70/75/89/100/115/125/140/150/211.5 (for hinged windows only radii in red are available)
- Fastenings visible on the exterior window flange
- 4mm, 6mm or 8mm single glazed
- Fixed, hinged and hopper windows only

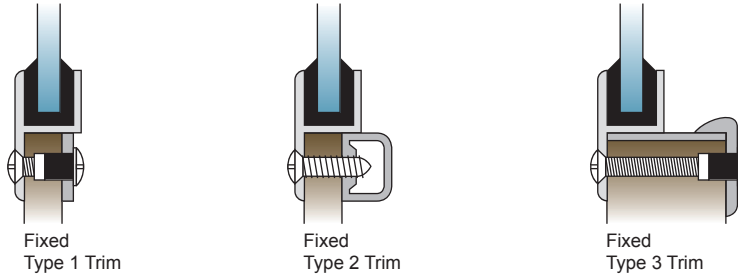

Section D

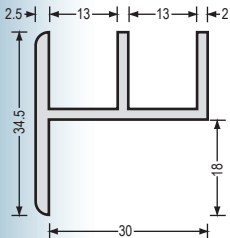

- Bend radii (mm): 47.5/50/57/63.5/70/75/89/100/115/125/140/150/211.5 (for hinged windows only radii in red are available)
- Fastenings visible on the exterior window flange
- 4mm, 6mm or 8mm single glazed suitable for all window styles. Only 6mm glazing for sliding & hopper windows
- Double-glazed to 22mm total thickness for fixed, hinged and hopper windows only

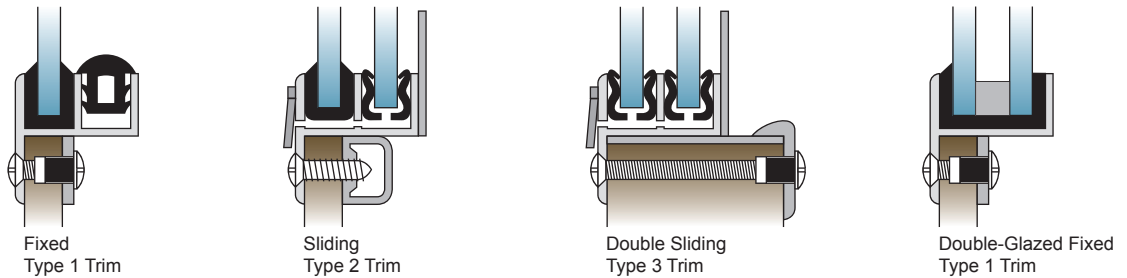

Section HS

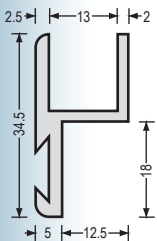

- Bend radii (mm): 63.5/70/75/89/100/115/125/140/150 (for hinged windows only radii in red are available)
- Exterior fastenings hidden by a decorative plastic trim
- 4mm, 6mm or 8mm single glazed for fixed, hinged and hopper windows only

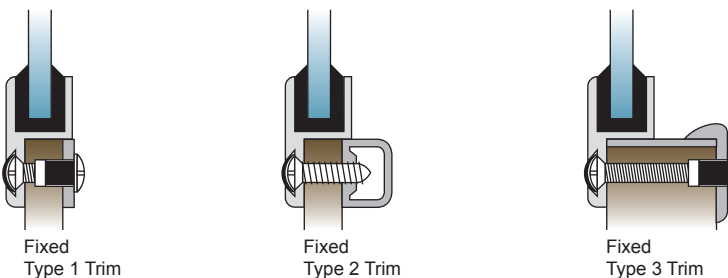

Section HD

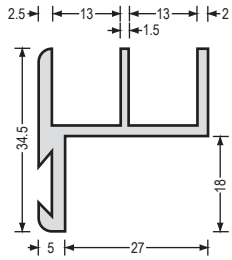

- Bend radii (mm): 63.5/70/75/89/100/115/125/140/150 (for hinged windows only radii in red are available)
- Exterior fastenings hidden by a black, white or grey decorative plastic trim
- 4mm, 6mm or 8mm single glazed suitable for all window styles. Only 6mm glazing for sliding & hopper windows
- Double-glazed to 22mm total thickness for fixed, hinged and hopper windows only

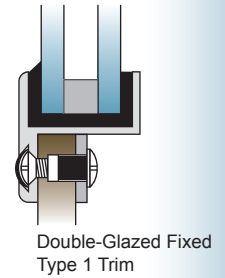
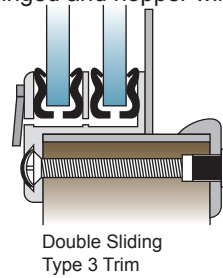
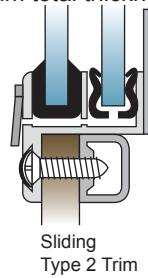
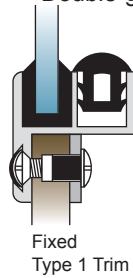

Section V

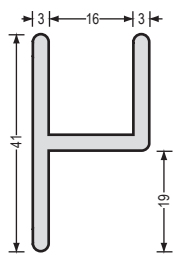

- Bend radii (mm): 50/63.5/75/89/100/115/125/140/150 (for hinged windows only radii in red are available)
- Fastenings visible on the exterior window flange
- 8mm, 10mm or 12mm single glazed for fixed, hinged and hopper windows only

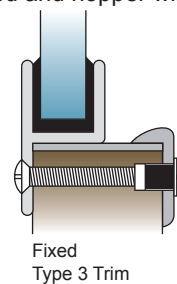
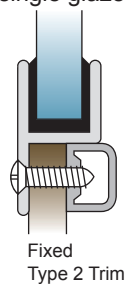
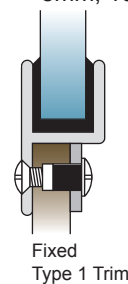

Section W

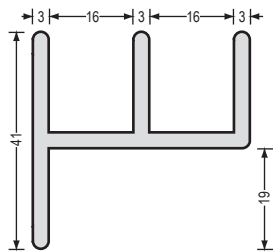

- Bend radii (mm): 63.5/75/89/100/115/125/140/150 (for hinged windows only radii in red are available)
- Fastenings visible on the exterior window flange
- 10mm single glazed suitable for sliding, half-drop and full-drop windows
- 8mm, 10mm or 12mm glazing for fixed and hinged windows
- Double-glazed to 29mm total thickness for fixed, hinged and hopper windows only

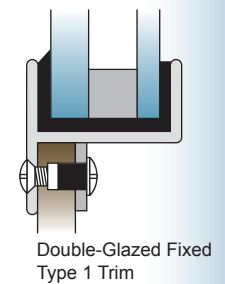
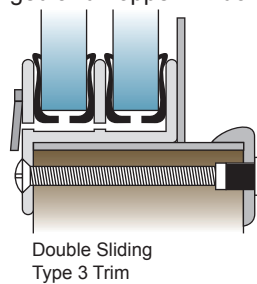
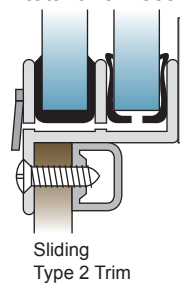
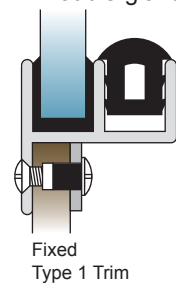

FRAMELESS HINGE OUT SECTION

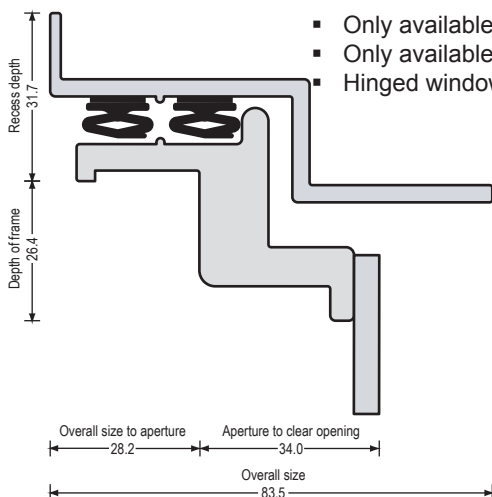

- Only available with mitred corners
- Only available with double glazed units fitted (Unit depth = 28mm)
- Hinged windows only

Drain hole through structure

Double synthetic rubber seal

No. 8 self-tapping screw

CLAMP FRAME SECTION DATA

Clamp frames mark a significant step forward in the design of aluminium marine windows. They are ideal for fitting to either aluminium or steel structures.

Clamp frames are fastened from the inside of the vessel by an internal clamp ring which is clamped to the external frame with stainless steel screws. The heads of the screws are concealed by a decorative plastic trim so that the fastenings are not visible from either the interior or exterior of the vessel.

Our customers report a reduction in fitting times of over 50% when compared to a standard bolt on window and as the structure is not pierced there is virtually no possibility of corrosion between the frame and the structure.

There are two clamp styles available:

Standard Clamp Sections - Suitable for most window sizes and styles.

The Standard Clamp Section range includes four different frame sections to accommodate fixed, sliding and double-glazed units of varying glass thicknesses.

All of the Standard Clamp Section range have identical exterior profiles, so that you can mix requirements for thicker glazed windows at the front of the vessel with thinner glazed side windows without affecting the external appearance of the windows.

The Standard Clamp Sections have two interior trims available to accommodate 3mm to 15mm walls (Type 1 Trim) and 10mm to 25mm walls (Type 2 Trim).

Lite Clamp Section - Suitable for smaller windows with tighter bend radii.

The Lite Clamp Section is specifically designed to enable smaller windows with tighter bend radii to utilise clamp frame technology. The smaller exterior profile also makes the Lite Clamp frame a more attractive and appropriate choice in smaller vessels for which larger frame sections may appear obtrusive.

The Lite Clamp Section has two different interior trims available to accommodate 4mm to 15mm walls (LC1 Trim) and 13mm to 25mm walls (LC2 Trim).

Standard Clamp Frame Interior Trim Types

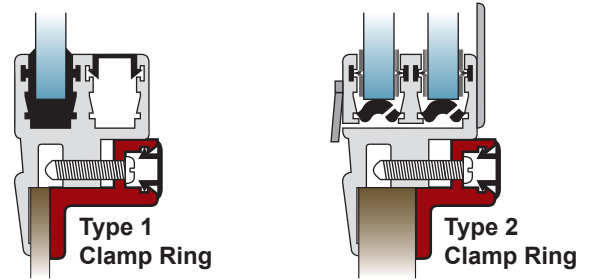

Lite Clamp Frame Interior Trim Types

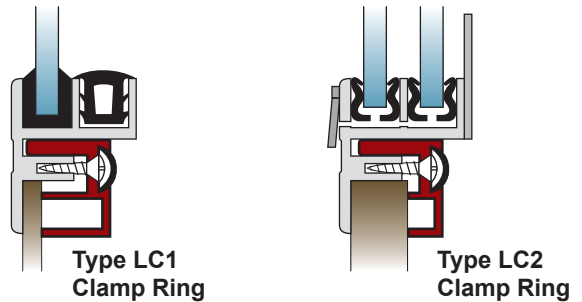

Standard Clamp Section 6-8

- Bend radii (mm): 100
- Available with 2 clamp ring options to accommodate structure thicknesses between 3mm and 20mm
- No exterior fastenings. Interior fastenings hidden by a decorative plastic trim
- Sliding windows supported by a hard plastic extrusion for free and easy movement, ideal for large sliding windows
- 6mm or 8mm single glazed suitable for all window styles. Thicker single glazed windows can be provided by using double-glazed clamp sections (see page 23)
- Double-glazed to 22mm total thickness (fixed, hinged and hopper windows only)
- Fastenings are M5 self-tapping machine screws

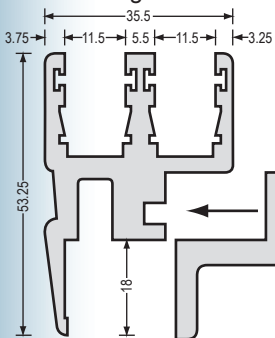

Type 1 Clamp Ring
3-10mm structure

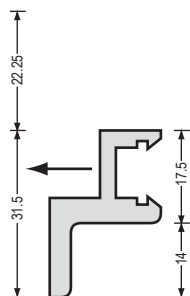

Type 2 Clamp Ring
10-20mm structure

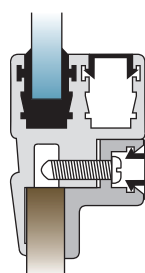

Fixed
Type 2

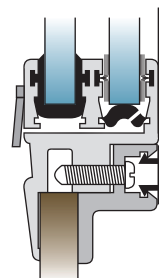

Sliding
Type 2

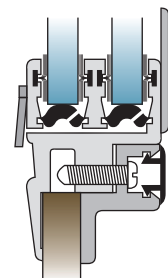

Double Sliding
Type 2

Standard Clamp Section 10-12

- Bend radii (mm): 80/90/100 (for hinged windows only radii in red are available)
- Available with 2 clamp ring options to accommodate structure thicknesses between 3mm and 25mm
- No exterior fastenings. Interior fastenings hidden by a decorative plastic trim
- Sliding windows supported by a hard plastic extrusion for free and easy movement, ideal for large sliding windows
- 10mm or 12mm single glazed suitable for all window styles
- Fastenings are M5 self-tapping machine screws

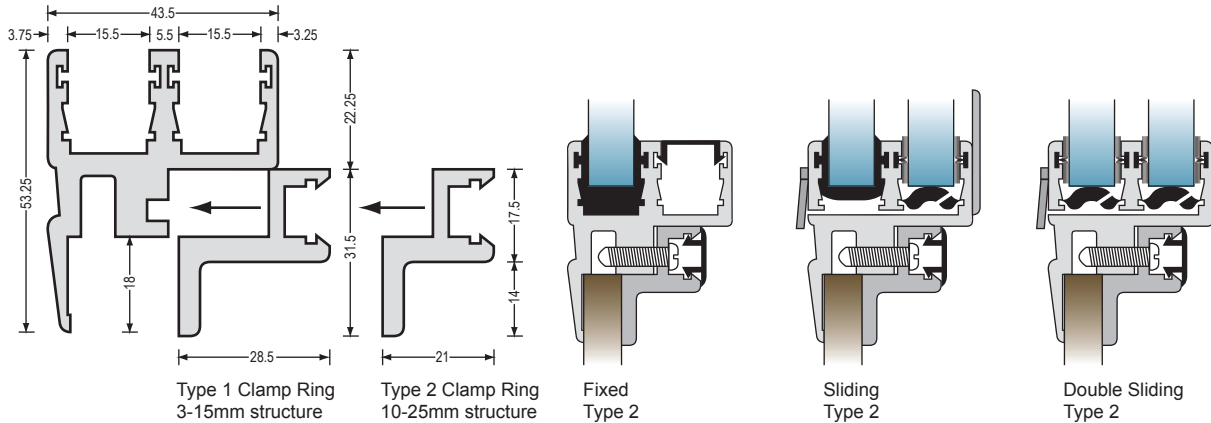

Standard Clamp Sections 6-8 and 10-12 Double Glazed

- Bend radii (mm): 80/90/100 (for hinged windows only radii in red are available)
- For double-glazing with an external pane up to 10mm thick and a 6mm internal pane (fixed, hinged and hopper windows only)
- Available with 2 clamp ring options to accommodate structure thicknesses between 3mm and 25mm
- No exterior fastenings. Interior fastenings hidden by a decorative plastic trim
- Fastenings are M5 self-tapping machine screws

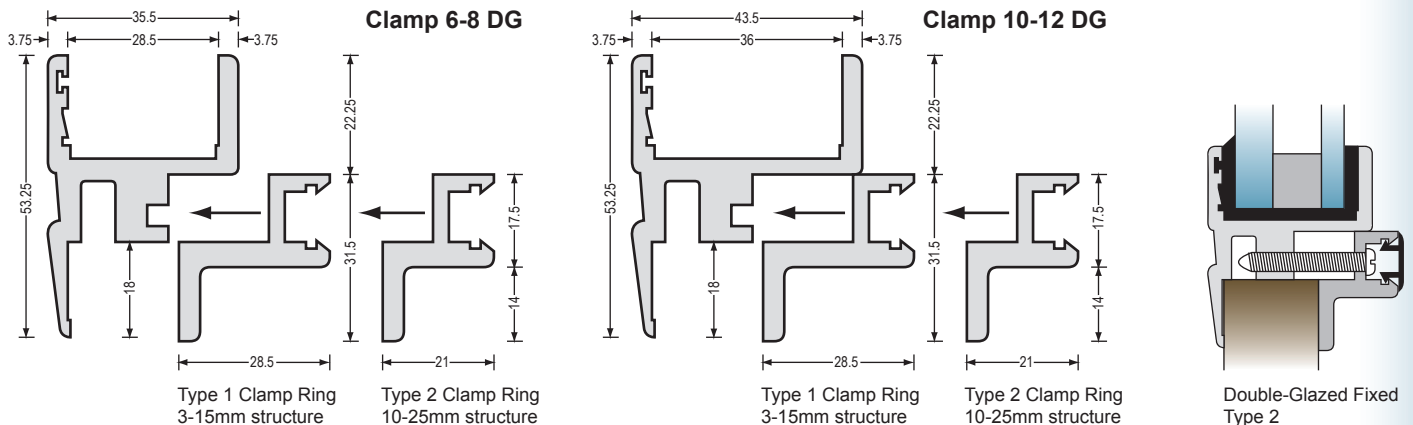

Lite Clamp Section

- Bend radii (mm): 63.5/75/80/90/100 (for hinged windows only radii in red are available)
- Available with 2 clamp ring options to accommodate structure thicknesses between 4mm and 25mm
- No exterior fastenings. Interior fastenings hidden by a decorative plastic trim
- 6mm or 8mm single glazed suitable for all window styles
- Double-glazed to 22mm total thickness (fixed, hinged and hopper windows only)
- Fastenings are No.6 self-tapping screws

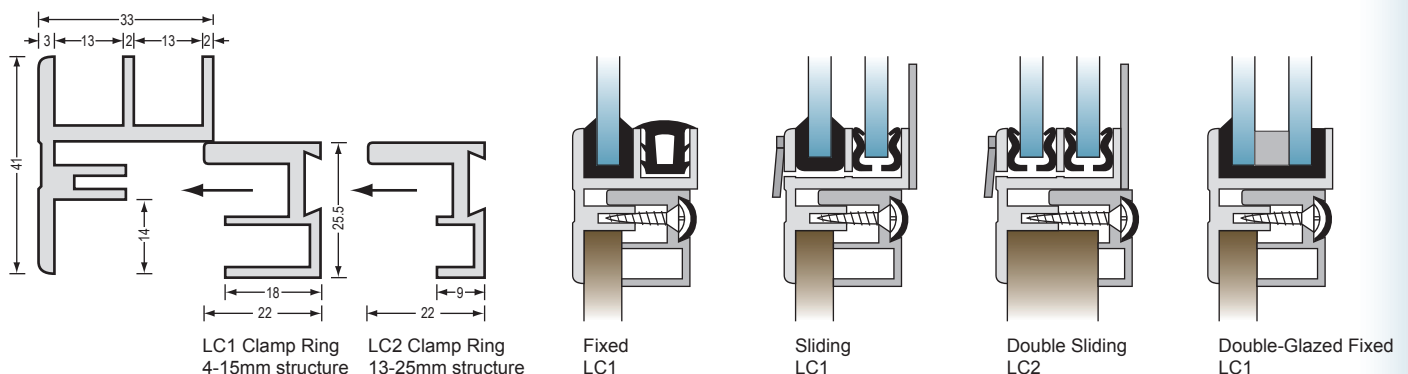

DOOR FRAME SECTION DATA

Our hinged doors employ the same clamp frame technology as our clamp window frames, which allows easy and rapid fitting of the doors to the vessel structure. The differences between the Heavy and Light Duty Doors are as follows:

FEATURE	HEAVY DUTY DOOR	LIGHT DUTY DOOR
External frame	Welded for extra stiffness and strength	Fishplated and screwed
Seals	Double synthetic rubber seal	Single synthetic rubber seal
Dogs	Optional dogs to improve watertightness	Dogs not available
Hinges	Stainless steel with bronze pin	Moulded nylon with stainless steel pin
Locks	Stainless steel lock designed for use in harsh environment	Stainless steel lock, designed for use in protected environment

Where a high degree of weathertightness is required, because the door will be exposed to the elements, the heavy duty door should be specified. The light duty door is appropriate for use as a sheltered external door opening onto the aft deck or as an interior door.

Heavy Duty Door Data

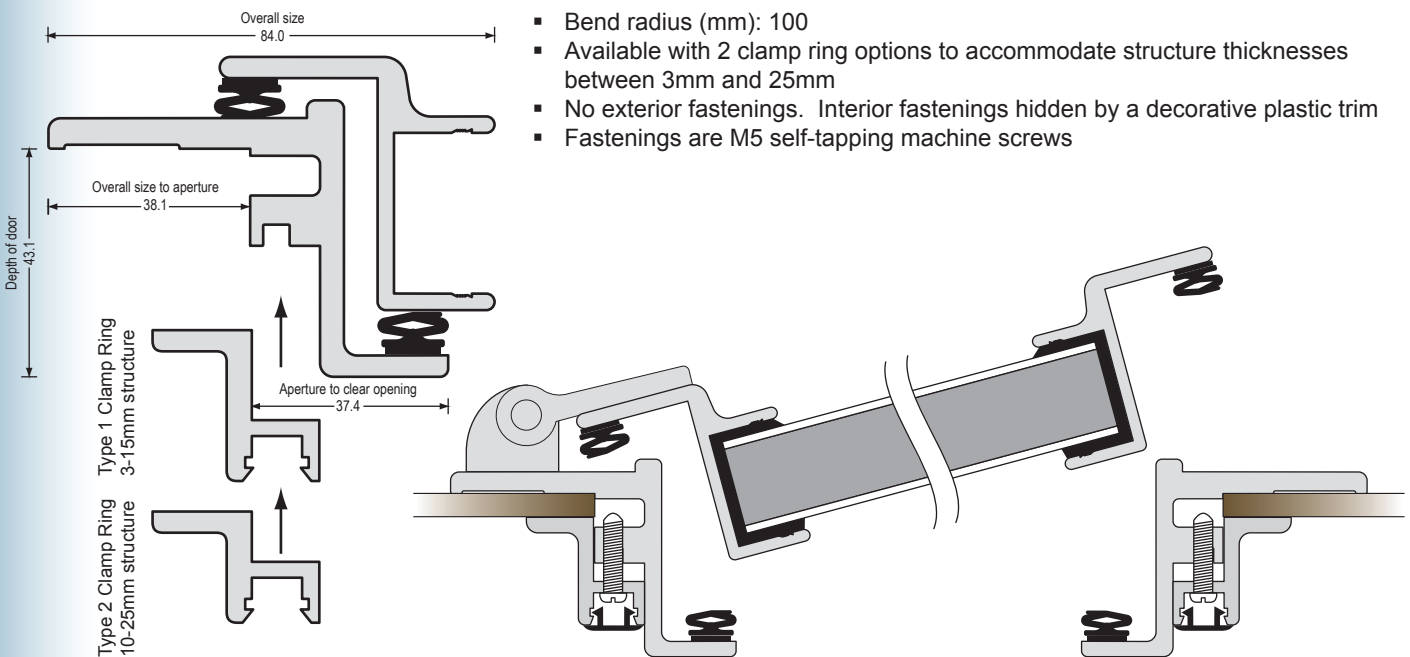

Light Duty Door Data

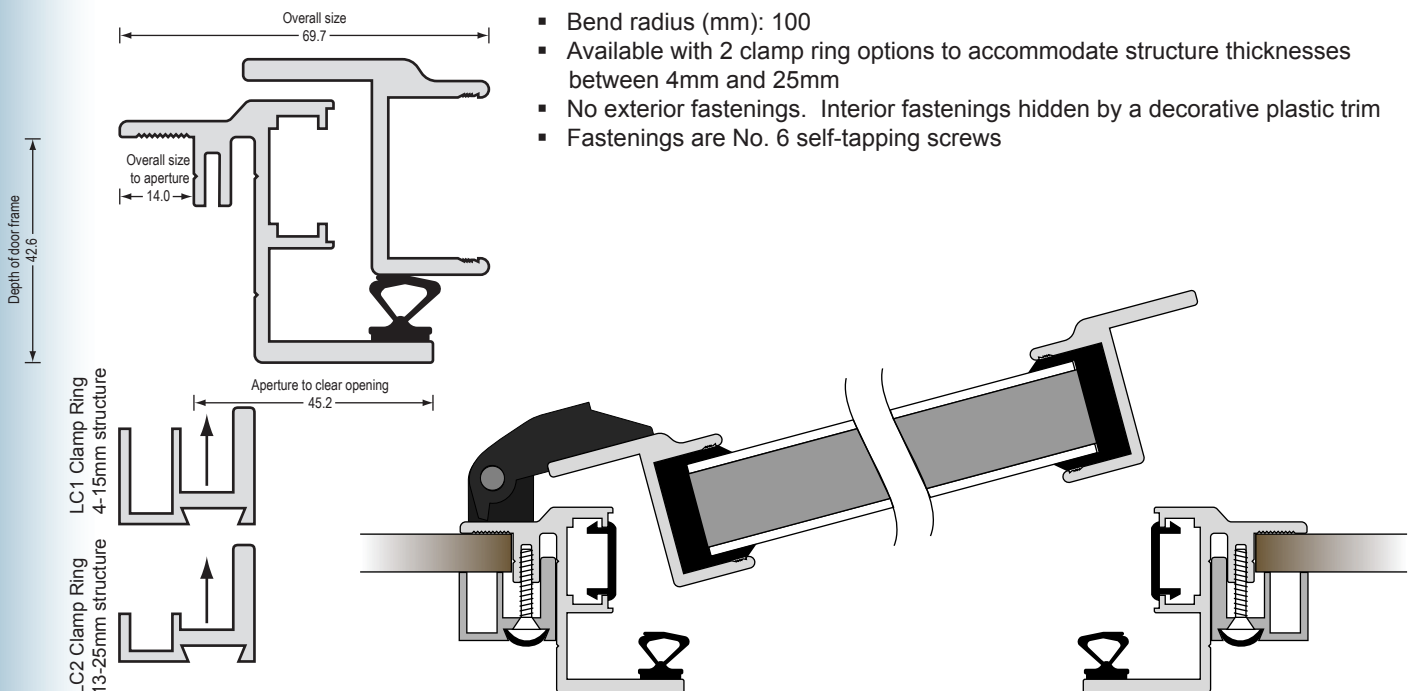

Bulkhead Sliding Door Data

- Only available with mitred corners
- Fastenings to bulkhead are covered with a decorative plastic trim

Top Frame

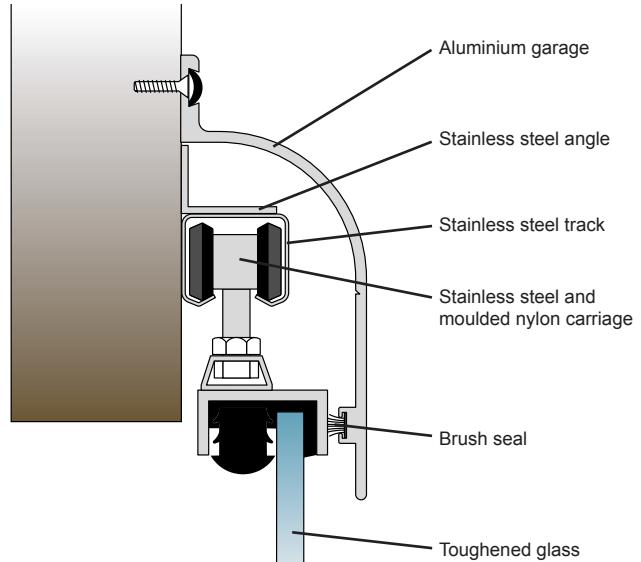
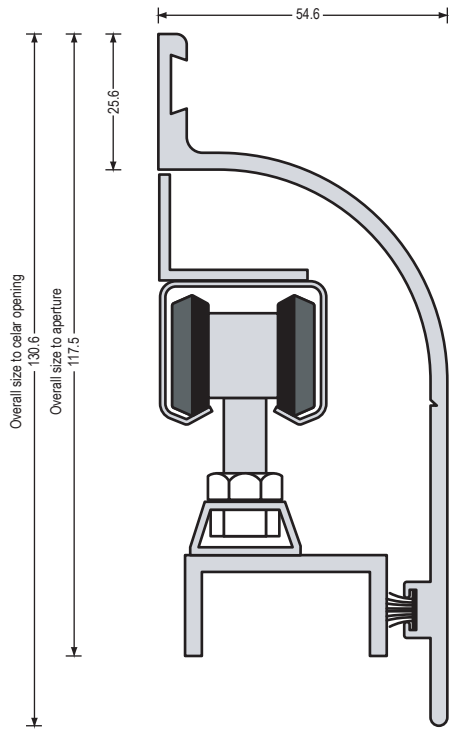

Bottom Frame

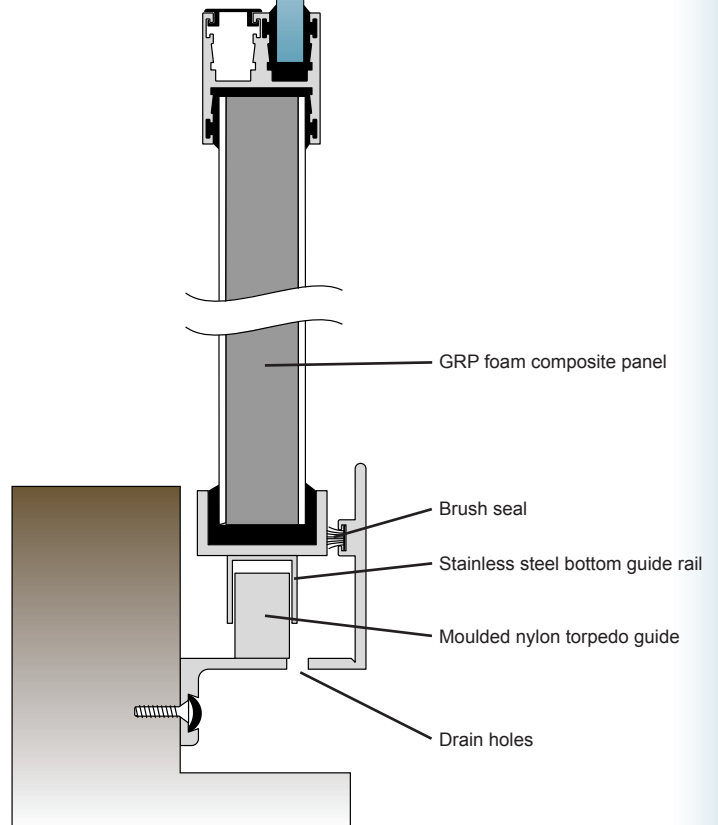
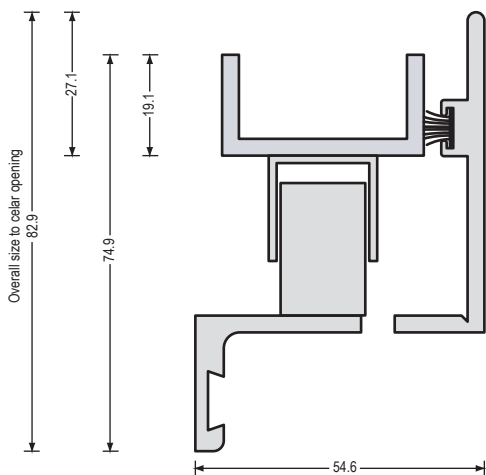

MOONLIGHT HATCHES

Houdini Marine Windows Limited are proud to be exclusive distributors for Moonlight products in the United Kingdom and Eire. With the inclusion of Moonlight's modern acrylic glazed hatches and portlights to our portfolio, Houdini Marine Windows now have a complete 'one stop shop' for all glazing requirements. All Moonlight hatches and portlights are certified in accordance with 94/25/EC & ISO 12216. A full detailed brochure of the Moonlight range is available separately.

Offshore Hatch (Series 62 and 63)

Moonlight's Offshore Hatch range features anodised aluminium frames, with grey tinted acrylic and friction hinges that allow the hatch to be opened to any intermediate position up to 180 degrees. There are no stay arms or other obstructions to impede access in or out of the hatch and no sharp edges for spinnakers to foul on. The hatches can be opened from inside and outside and are lockable from inside for security. These hatches are available in a comprehensive range of sizes to suit most boats (separate brochure detailing sizes available on request).

The series 62 includes a 12.5mm spigot on the base frame. The series 63 has a 25mm spigot on the base frame.

Features

- Marine grade aluminium, silver satin anodised as standard
- Grey tinted acrylic as standard
- Inside / outside opening handles (lockable from inside) as standard
- Friction hinge holds hatch open in intermediate positions without the need for stay arms etc.

Options

- Clear or coloured acrylic
- Polyester powder coated or black anodised frame
- Aluminium or plastic inner frame
- Flyscreen (must be fitted in conjunction with inner frame)
- External key lock



Powerboat Hatch (Series 55)

Moonlight's Powerboat Hatch range features anodised aluminium frames, with grey tinted acrylic glazing and adjustable stay arms that allow the hatch to be locked in variable open positions. These hatches have a very low profile to the deck and can be opened from inside and outside and are lockable from inside for security. These hatches are available in a comprehensive range of sizes to suit most boats (separate brochure detailing sizes available on request).

Features

- Marine grade aluminium, silver satin anodised as standard
- Grey tinted acrylic as standard
- Inside / outside opening handles (lockable from inside) as standard
- Adjustable stay arms that allow the hatch to be locked in variable open positions

Options

- Clear or coloured acrylic
- Polyester powder coated or black anodised frame
- Aluminium or plastic inner frame
- Flyscreen (must be fitted in conjunction with inner frame)

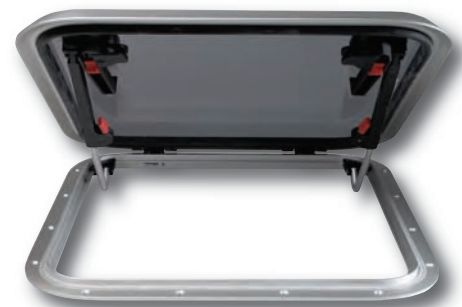

Compact Flush Hatch

Moonlight have introduced a range of flush fitting deck hatches which give superyacht styling at affordable prices. The compact flush hatch utilises the offshore hatch base with a dark grey tinted acrylic lid which is designed to be fitted flush to the surrounding teak decking. Drainage is achieved using preformed channels under the teak decking.



Features

- Dark grey tinted acrylic
- Stainless steel gas strut
- Inside / outside opening handles (lockable from inside) as standard

Options

- Flush handles openable from outside with winch handle
- Aluminium or plastic inner frame
- Flyscreen (must be fitted in conjunction with inner frame)



Portlights (Series 91 and 92)

Moonlight portlights are available as either fixed or inward opening and are manufactured to international standards to suit a range of structures from 1mm to 42mm (depending on trim type). Portlights are fitted using clamp frame technology requiring no drilling of holes through your structure, and incorporate a fitted seal giving excellent watertight fitting. Smaller models come with a flyscreen as standard, larger models offer the flyscreen as an optional extra.

The series 91 are opening portlights. Series 92 are fixed portlights.

Features

- Low profile (only 8mm beyond the structure)
- Hinges and locking handles made from high grade nylon
- Friction hinges allowing portlight to remain open in any intermediate position
- Frame and seal designed to minimise effect of water sitting in the frame when heeling
- Grey tinted acrylic as standard
- Fixing bolts supplied
- Aluminium inner trim

Options

- Plastic inner trim
- Clear acrylic
- Polyester powder coated or black anodised aluminium frame
- Polished silver anodised aluminium frame



H OUDINI



H OUDINI

**Houdini Marine Windows Ltd.
Hallmark Industrial Estate
Southminster
Essex
CM0 7EH
England**

**Tel: +44 (0)1621 773590
Fax: +44 (0)1621 773852**

**sales@houdini-marine.co.uk
www.houdini-marine.co.uk
Australian Distributor: DeckHardware
www.deckhardware.com.au**

